



SKF 25 – good preparation is everything

Good work preparation, good results. This universal bevel edge milling machine with integrated tube enables perfect weld preparation.

SKF 25 - This new hand-guided BDS machine is ideally suited for easy and quick preparation of welded seams. On account of its low weight of 22 Kg, it is easy to handle and can be guided exactly and easily with smooth-running rollers. The end result is uniformly milled edges for perfect welded seams.

The SKF 25 of BDS is suitable for machining

- ▶ normal steel
- ▶ stainless steel
- ▶ aluminium
- ▶ non-ferrous metals

The chamfer angle can be adjusted continuously from 15° to 60° with a maximum chamfer width of 15 mm.

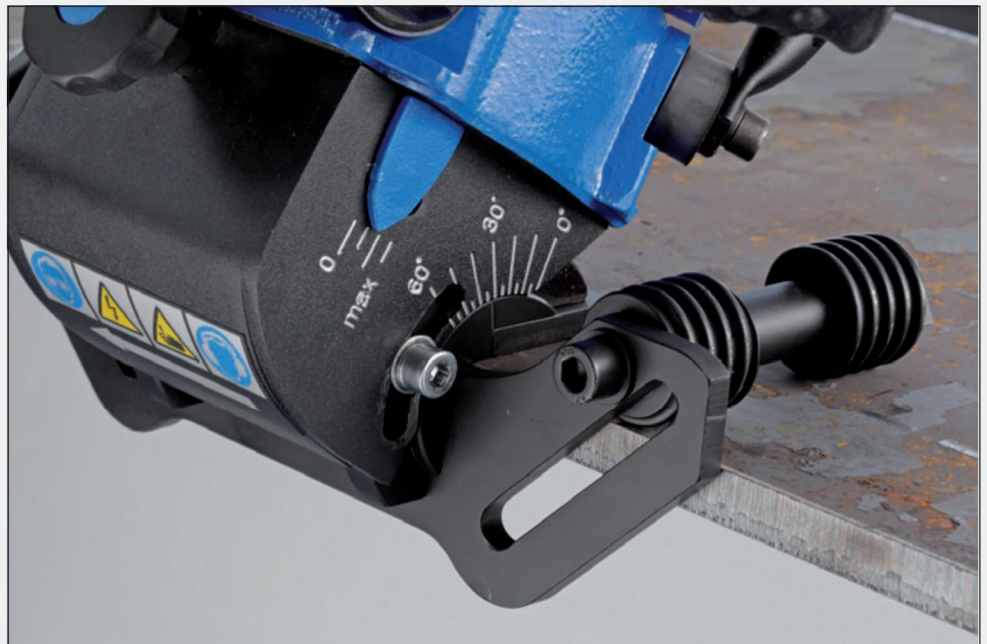

Large guide rollers and a continuous angle adjustment from 15 to 60° render the system practical.

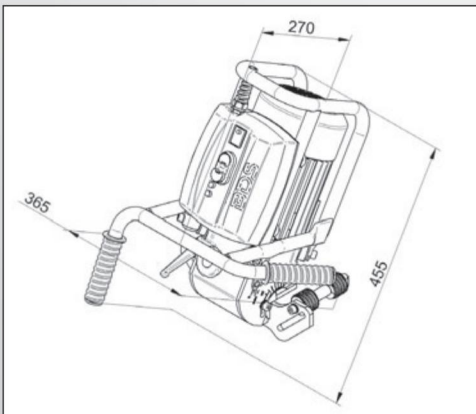

Technical drawing



Edge processing of pipes in a vertical position.

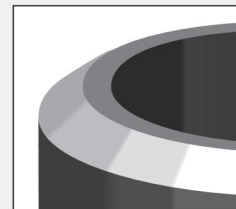









Milling edge

The advantages of the SKF 25

- > Wide chamfers – up to 15 mm
- > Continuous angle adjustment – from 15 to 60°
- > Handy – with ergonomic handle arrangement
- > Easily guided – with guide rollers



SPECIFICATION

	Motor output:	1.1 kW
	Voltage:	220-240 V AC, 50-60 Hz
	Feed:	manual
	Speed range 1:	2850 min ⁻¹
	Chamfer width:	15 mm
	Angle adjustment:	15 – 60° continuously
	Safety:	automatic overload cutout / restart lockout
	Weight:	22 kg
	Tools:	Arbor milling cutter, double-row, with 10 sintered carbide reversible disks

ACCESSORIES

ORDER NO.

Arbor milling cutter

ZFR 250 1 pc.

Carbide reversible disks are not included in delivery. Please clearly order them as an extra.

Carbide reversible disks

SHM 800 1 pc.

SHM 400-E 1 pc.

1 set = 10 carbide reversible disks



Arbor milling cutter ZFR 250



Carbide reversible disk



Angle adjustment 15 - 60°

ORDER NO.

SKF 25 / 230 Volt

SKF 25 / 110 Volt

SCOPE OF DELIVERY

1 Bevel edge milling machine

1 Carry case

1 Arbor milling cutter ZFR 250 with
10 carbide reversible disks

SHM 800

1 Offset screwdriver SW 8

1 Operating manual

1 Screwdriver TX 15