

MAB 825  
MAB 845

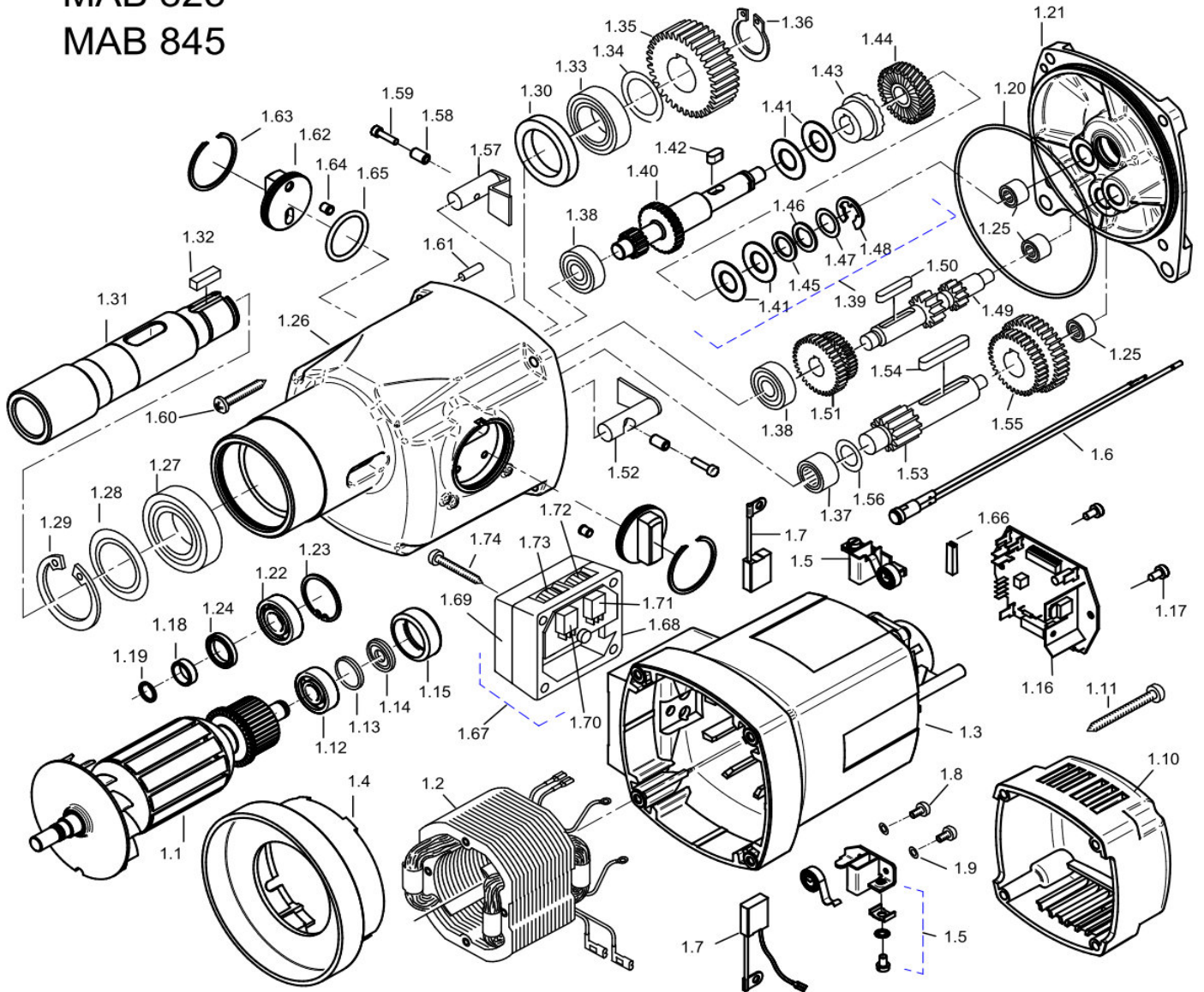

Pos. No.	Article no.	Description	pc
1.1.1	5013911	Armature 110V	1
1.1.2	5050061	Armature 230 V	1
1.2.1	5012551	Field coil 110 V	1
1.2.2	5011611	Field coil 230V	1
1.3.1	5050051	Motor housing complete until February 2012	1
1.3.2	5050031	Motor housing complete since February 2012	1
1.4	5011091	Air conducting ring	1
1.5	5011601	Carbon brush holder complete	2
1.6	5015011	Control light for carbon brush	1
1.7.1.1	5012541	Carbon brush 6,3x16x20 L41F13 110V until February 2012	2
1.7.2.1	5012542	Set of carbon brushes 6,3x16x20 L41F13 110V since February 2012	1
1.7.1.2	5012531	Carbon brush 6,3x16x20 L85F10 230V until February 2012	2
1.7.2.2	5012532	Set of carbon brushes 6,3x16x20 L85F10 230V since February 2012	1
1.8	5013991	Self tapping screw ZM4x12	4
1.9	5013981	Corrugated spring washer B4 DIN 137	4
1.10	5011531	Cap for motor housing	1
1.11	5010581	Screw HC 4,8x45 DIN 7981	4
1.12	5011301	Ball bearing 6000 2Z	1
1.13	5011741	Pressboard washer	1
1.14	5011571	Ring magnet	1
1.15	5011561	Bearing cap	1
1.16.1	5014771	Motor board 110 V	1
1.16.2	5011541	Motor board 230 V	1
1.17	5010951	Screw HF 3,9x9,5 DIN 7981	2
1.18	5050221	Seal bush	1
1.19	5050181	Circlip ring SW 11	1
1.20	5050091	Transmission seal 106x2	1
1.21	5050081	Shield plate	1
1.22	5012501	Ball bearing 6001 2RS	1
1.23	5010271	Circlip ring 28/1,2 DIN 472	1
1.24	5013601	Shaft seal KEIV 15x21x3	1
1.25	5010351	Needle bearing HK 0810 DIN 625	3
1.26	5050121	Gearbox housing	1
1.27	5012331	Ball bearing 6006 2RS	1
1.28	5011251	Washer for ball bearing 6006 2Z	1
1.29	5011241	Circlip ring 55/2 DIN 472	1
1.30	5050111	Shaft seal WASY 30x42x7	1
1.31	5011221	Spindle	1
1.32	5011161	Spring B6x6x20 DIN 6885	1
1.33	5011191	Ball bearing 6005 2RS	1
1.34	5011181	Washer 25x35x0,1 DIN 988	1
1.35	5011811	Spindle wheel	1
1.36	5011151	Circlip ring 24/1,2 DIN 471	1
1.37	5011261	Needle bearing RNA 4900	1
1.38	5011011	Ball bearing 6000	2

Pos. No.	Article no.	Description	pc
1.39	5050071	Clutch complete	1
1.40	5050101	Intermedium shaft 1	1
1.41	5011331	Spring 28x12,2x1	4
1.42	5011341	Spring A5x5x10 DIN 6885	1
1.43	5011351	Half of clutch	1
1.44	5050171	Clutch wheel	1
1.45	5011391	Washer 1	1
1.46	5050201	Washer 12x18x0,2 DIN 988	1
1.47	5011381	Washer 2	1
1.48	5011411	Circlip ring 9 DIN 6799	1
1.49	5011841	Intermedium gear wheel 2	1
1.50	5010501	Spring A5x5x28 DIN 6885	1
1.51	5011281	Gear wheel assembly 1	1
1.52	5050131	Clutch 2	1
1.53	5011851	Intermedium shaft 3	1
1.54	5011881	Spring A6x6x40 DIN 6885	1
1.55	5011791	Gear wheel assembly 2	1
1.56	5011271	Washer for needle bearing RNA 4900	1
1.57	5050161	Clutch 1	1
1.58	5014581	Sleeve	2
1.59	5014531	Hexagon socket with pilot recess M4 x16 DIN 6912	2
1.60	5010911	Screw HC 5,5x38 DIN 7981	4
1.61	5050191	Pin 5 x12 DIN 1474	1
1.62	5014541	Gear change	2
1.63	5014551	Circlip ring SB42	2
1.64	5014561	Pressure piece	2
1.65	5014601	O-Ring 36x1,5	2
1.66	5014741	Isolating grommet	1
1.67	5011981	Housing for potentiometer complete	1
1.68	5011661	Bottom part of housing for potentiometer without potentiometer and speed control	1
1.69	5011671	Cover for housing of potentiometer	1
1.70	5011681	Potentiometer for power control 1 kOhm 7V	1
1.71	5011401	Potentiometer for speed control 100 kOhm 2V	1
1.72	5010861	Adjustment wheel blue for speed control 2V	1
1.73	5011701	Adjustment wheel red for power control 7V	1
1.74	5011971	Countersunk screw 6x45 voltaic black	4

MAB 825

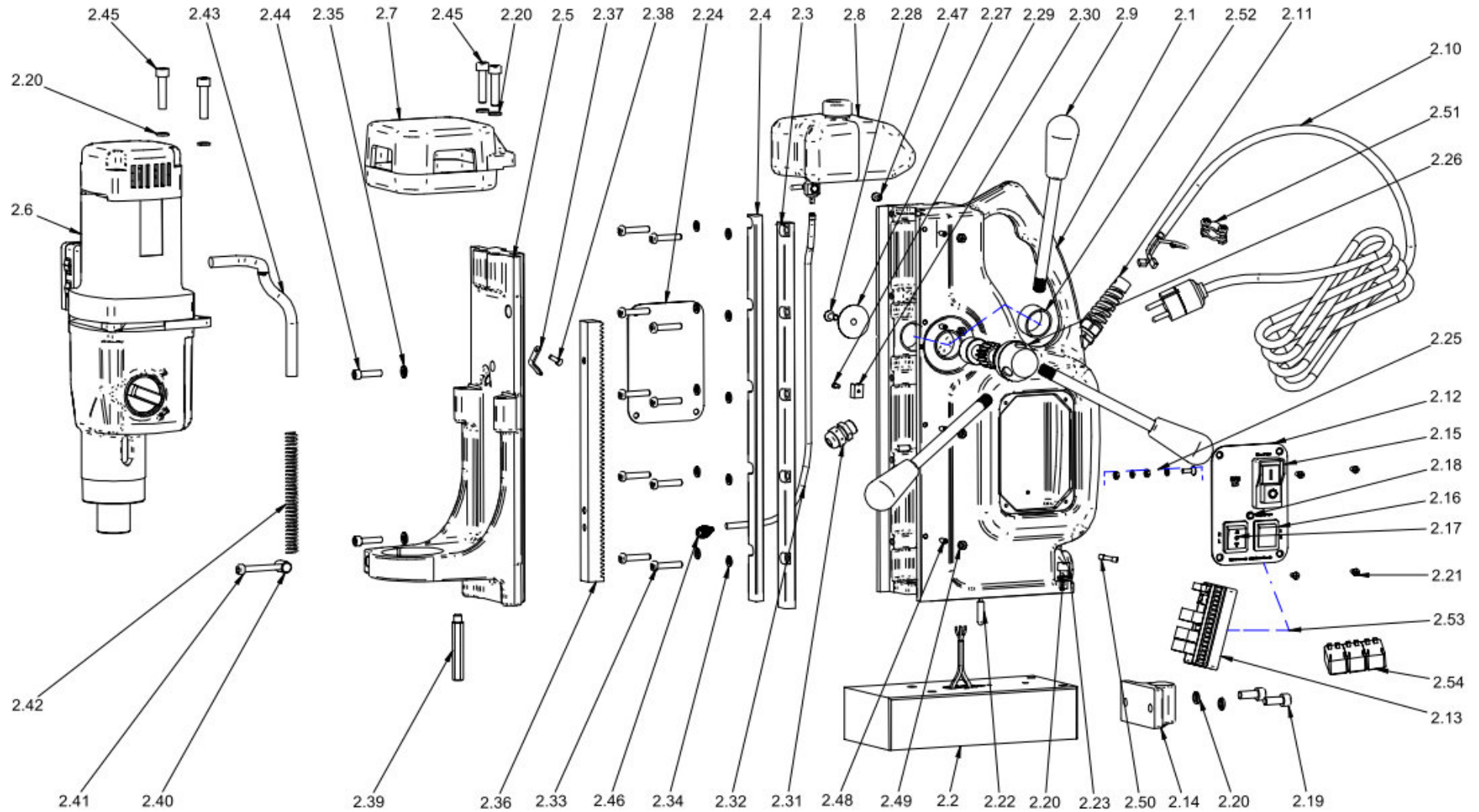

Pos. No.	Article no.	Description	pc
2.1.1	6050011	Housing M8 for guide rails one side glued, one side screwed unti January 2009	1
2.1.2	6050012	Housing M8 for guide rails both sides screwed since January 2009	1
2.2	6050031	Magnet (electric) with indicator M8	1
2.3	6050061	Guide rail right, screwed, 5 holes	1
2.4.1	6050281	Guide rail left, to be glued until January 2009	1
2.4.2	6050051	Guide rail left, screwed, 5 holes since January 2009	1
2.5	6050001	Slide with holder for gearbox	1
2.6.1.1	5050011	Motor complete 110V 1800W 4-Gears until April 2012	1
2.6.2.1	5018252	Motor complete 110V 1800W 4-Gears since April 2012	1
2.6.1.2	5050001	Motor complete 230V 1800W 4-Gears until April 2012	1
2.6.2.2	5008252	Motor complete 230V 1800W 4-Gears since April 2012	1
2.7	6050071	Cover for motor	1
2.8	6050081	Coolant reservoir with tap	1
2.9	6010542	Handle rod with knob	3
2.10.1.1	7010052	Connection cable 110 V with GB-plug	1
2.10.2.1	7010242	Connection cable 110V with US-plug	1
2.10.1.2	7010042	Connection cable 230V complete with plug	1
2.11	7010031	Mains cable gland PG 11	1
2.12.1	7011451	Switch plate front side for version 110V	1
2.12.2	7011471	Switch plate front side for version 230V	1
2.13.1	7010163	Control board with 3 Relais 110V	1
2.13.2	6012152	Control board with 3 Relais 230V	1
2.14	6010581	Magnet release assembly	1
2.15.1	7010111	Actuator 110V	1
2.15.2	7010801	Actuator 230V	1
2.16	7010142	Magnet switch, 4 connection terminals	1
2.17	7010482	Rocker switch right/left	1
2.18	7010101	LED display for indicator red/green incl. cable and frame	1
2.19	6050091	Cylinder head bolt M8x20 DIN 912	2
2.20	6010571	Spring washer 8,2 DIN 7980	10
2.21	7010081	Screw M4x8 DIN 966	8
2.22	6012171	Indicator with cable	1
2.23	6050101	Cylinder head bolt M8x30 DIN 912	4
2.24	7011831	Shield plate	1
2.25	7010061	Earthing complete	1
2.26	6050111	Shaft for gear wheel	1
2.27	6010221	Washer for gear wheel 10,5x35x1,5	1
2.28	6010231	Screw M6x16 ISO 7047	1
2.29	6050121	Screw HC 2,9x9,5 DIN 7983	1
2.30	6050131	Fixing device for coolant tube	1
2.31	7050011	Cable Gland PG 11	1
2.32	ZSS 200SL	Cooling tube blue, long 480 mm	1
2.33	6050141	Cylinder head bolt M6x25 DIN 7984	8
2.34	6013441	Disc 6,4x11x1,6 DIN 433	8
2.35	6010021	Spring washer 6,1 DIN 7980	2

<b>Pos. No.</b>	<b>Article no.</b>	<b>Description</b>	<b>pc</b>
2.36	6050161	Rack	1
2.37	6050171	Fixing device for cable	1
2.38	6050181	Screw with cross slot M3x8 DIN 7985	1
2.39	6050191	Stop pin L=70	1
2.40	6050201	Plug with thread	1
2.41	6010481	Cylinder head bolt M6x55 DIN 912	1
2.42	7050021	Cable protection	1
2.43	6050221	Motor cable 770 mm	1
2.44	6010111	Cylinder head bolt M6x25 DIN 912	2
2.45	6050241	Cylinder head bolt M8x35 DIN 912	4
2.46	ZSS 200K	Quick change coupling	1
2.47	4000121	Pressure piece	1
2.48	6010041	Adjusting screw M5x16 DIN 913	4
2.49	6010031	Nut M5 DIN 934	4
2.50	7010131	Fuse 2A, 5x20	1
2.51	4010291	Cord grip for connection cable	1
2.52	6013871	Bush bearing 28,05H7x32x16	2
2.53.1	7011861	Switch plate complete with PC board 3 relais 110V	1
2.53.2	7011741	Switch plate complete with PC board 3 relais 230V	1
2.54	7011851	Relais 30A for control board 110V	3

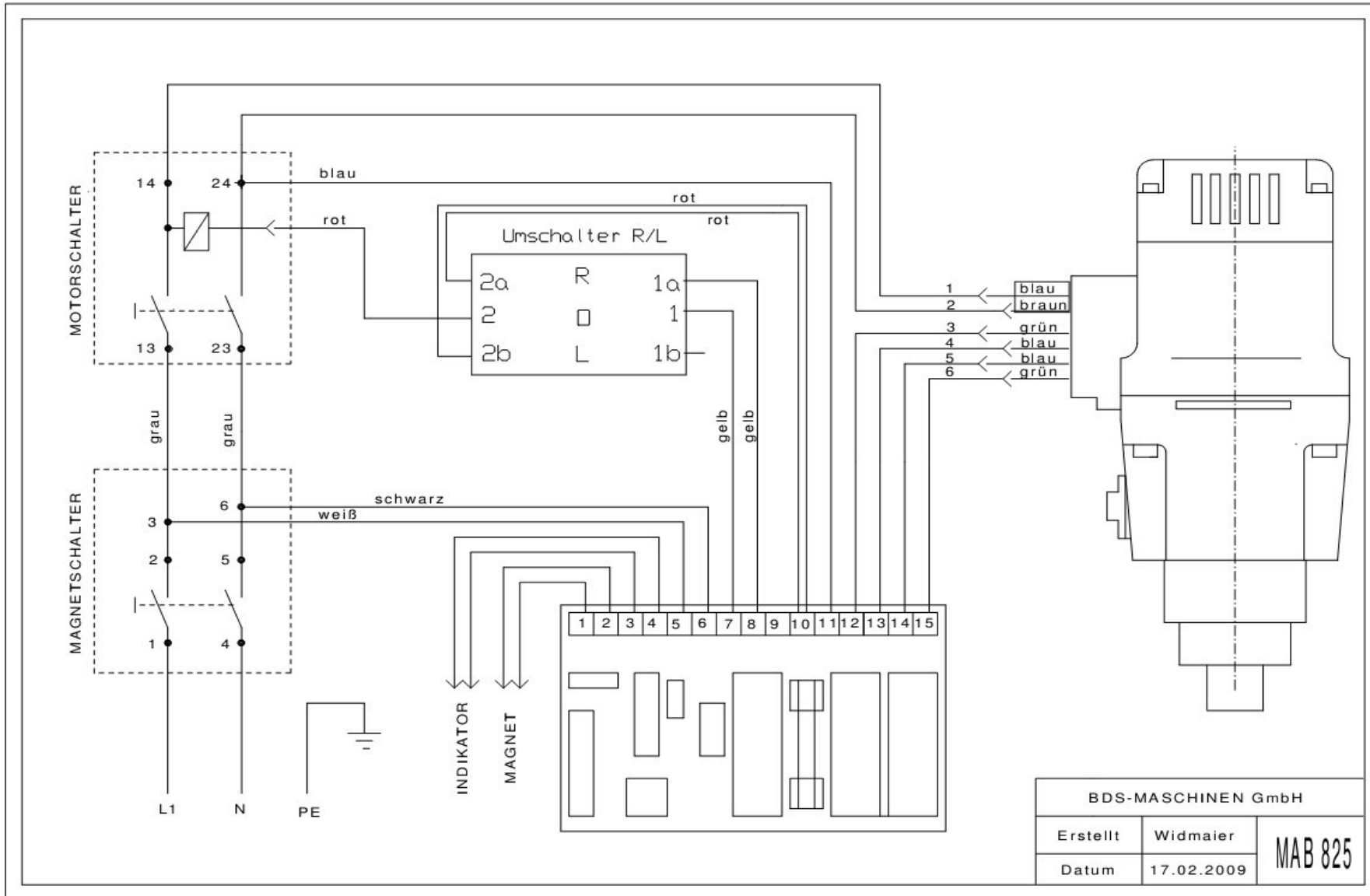

BDS-MASCHINEN GmbH		
Erstellt	Widmaier	MAB 825
Datum	17.02.2009	

