

MAB 1300.2 R/L

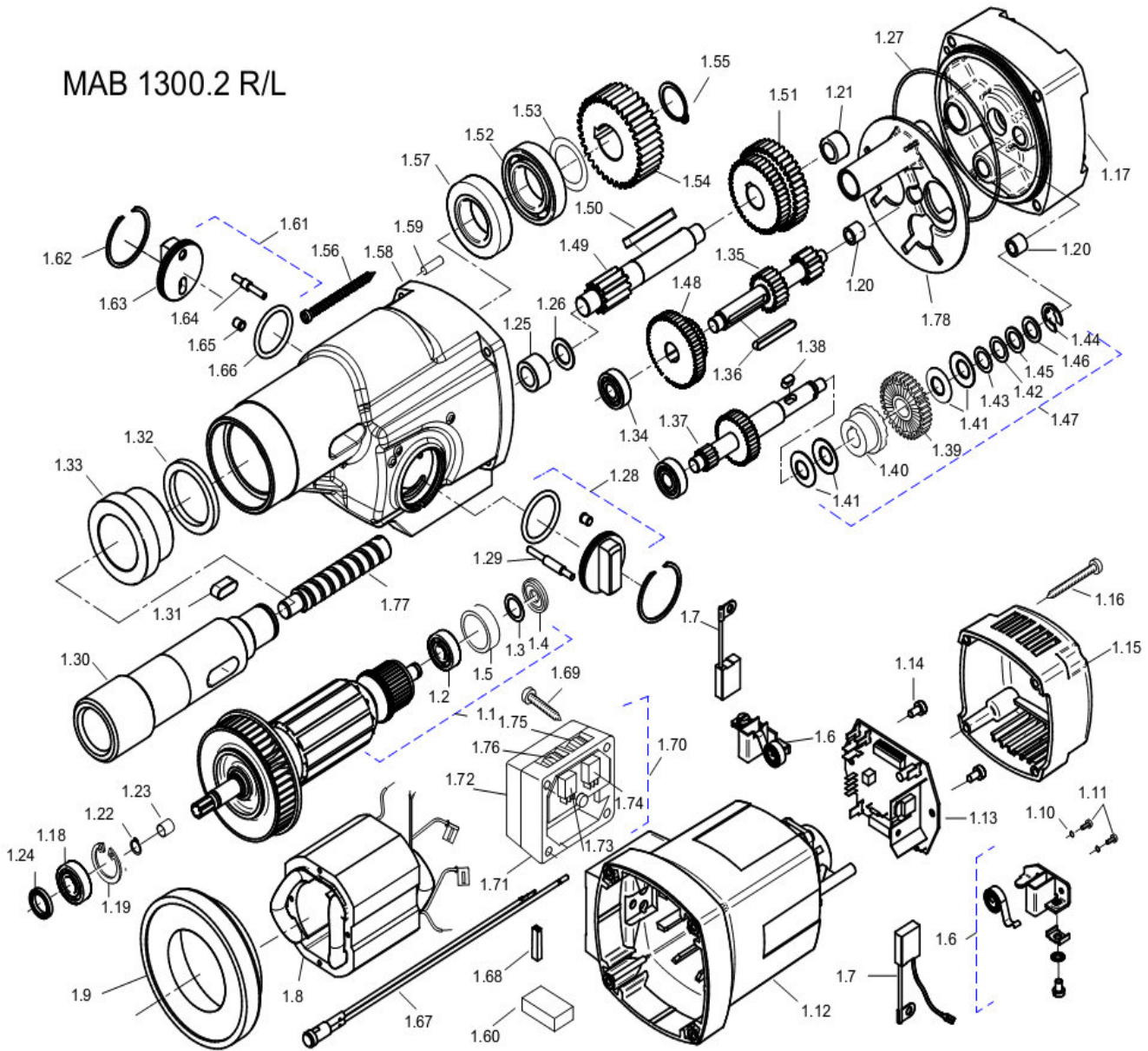

Pos. No.	Article no.	Description	pc
1.1.1	5013931	Armature 110V	1
1.1.2	5013921	Armature 230V	1
1.2	5011301	Ball bearing 6000 2Z	1
1.3	5013941	Seal ring 10x14x1	1
1.4	5013951	Ring magnet	1
1.5	5011561	Bearing cap	1
1.6	5011601	Carbon brush holder complete	2
1.7.1.1	5012541	Carbon brush 6,3x16x20 L41F13 110V until May 2012	2
1.7.2.1	5012542	Set of carbon brushes 6,3x16x20 L41F13 110V since May 2012	1
1.7.1.2	5012531	Carbon brush 6,3x16x20 L85F10 230V until May 2012	2
1.7.2.2	5012532	Set of carbon brushes 6,3x16x20 L85F10 230V since May 2012	1
1.8.1	5014402	Field coil 110V	1
1.8.2	5014401	Field coil 230V	1
1.9	5013971	Air conducting ring	1
1.10	5013981	Corrugated spring washer B4 DIN137	4
1.11	5013991	Self tapping screw ZM4x12	4
1.12.1	5011631	Motor housing until May 2012	1
1.12.2	5014781	Motor housing since May 2012	1
1.13.1	5014771	Motor board 110V	1
1.13.2	5011541	Motor board 230V	1
1.14	5010951	Screw HC 3,9x9,5 DIN 7981	2
1.15	5011531	Cap for motor housing	1
1.16	5010581	Screw HC 4,8x45 DIN 7981	4
1.17	5014031	Shield plate	1
1.18	5014041	Ball bearing 6201 LUZ	1
1.19	5014441	Circlip ring 32/1,2 DIN 472	1
1.20	5010351	Needle bearing HK 0810 DIN 625	2
1.21	5014411	Needle bearing HK 1212	1
1.22	5014421	Circlip ring 12/1 DIN 471	1
1.23	5014081	Bearing ring	1
1.24	5013601	Shaft seal KEIV 15x21x3	1
1.25	5011261	Needle bearing RNA 4900	1
1.26	5011271	Washer for needle bearing RNA 4900	1
1.27	5050091	Transmission seal 106x2	1
1.28	5014101	Gear change long	1
1.29	5014111	Pin for gear position, long	1
1.30	5014121	Spindle	1
1.31	5011161	Spring B6x6x20 DIN 6885	1
1.32	5014431	Felt washer for bearing	1
1.33	5014141	Axial needle bearing	1
1.34	5011011	Ball bearing 6000	2
1.35	5014151	Intermediate shaft 2	1
1.36	5014161	Spring 5x5x40	1
1.37	5014171	Intermediate shaft 1	1
1.38	5011341	Spring A5x5x10 DIN 6885	1
1.39	5011651	Clutch wheel 29 teeth - straight teeth	1

Pos. No.	Article no.	Description	pc
1.40	5011351	Half of clutch	1
1.41	5011331	Spring 28x12,2x1	4
1.42	5012651	Washer 12x18x0,2 DIN 988	1
1.43	5011391	Washer 1	1
1.44	5011411	Circlip ring 9 DIN 6799	1
1.45	5050201	Washer 12x18x0,2 DIN 988	1
1.46	5011381	Washer 2	1
1.47	5014231	Clutch complete	1
1.48	5014241	Gear wheel assembly 1	1
1.49	5014251	Intermediate shaft 3	1
1.50	5014261	Spring A6x6x50 DIN 6885	1
1.51	5014271	Gear wheel assembly 2	1
1.52	5012331	Ball bearing 6006 2RS	1
1.53	5011181	Washer 25x35x0,1 DIN 988	1
1.54	5014281	Spindle gear wheel	1
1.55	5014291	Circlip ring 25/1,2 DIN 471	1
1.56	5014301	Screw HC 5,5x80 DIN 7981	4
1.57	5014311	Shaft seal 38x48x6	1
1.58	5014321	Gearbox case	1
1.59	5011481	Pin 5x16 DIN 1474	1
1.60	5014341	Block 30x20x15	1
1.61	5014351	Gear change short	1
1.62	5014551	Circlip ring SB42	2
1.63	5014371	Gear change	2
1.64	5014381	Pin for gear position, short	1
1.65	5014561	Pressure piece	2
1.66	5014601	O-Ring 36x1,5	2
1.67	5015011	Control light for carbon brush	1
1.68	5014741	Isolating grommet	1
1.69	5011971	Screw 6x45 voltaic black	4
1.70	5011981	Housing for potentiometer complete	1
1.71	5011661	Bottom part of housing for potentiometer without potentiometer and speed control	1
1.72	5011671	Cover for housing of potentiometer	1
1.73	5011681	Potentiometer for power control 1 kOhm 7V	1
1.74	5011401	Potentiometer for speed control 100 kOhm 2V	1
1.75	5010861	Adjustment wheel blue for speed control 2V	1
1.76	5011701	Adjustment wheel red for power control 7V	1
1.77	5014751	Hoisting spindle	1
1.78	5014761	Gear partition	1

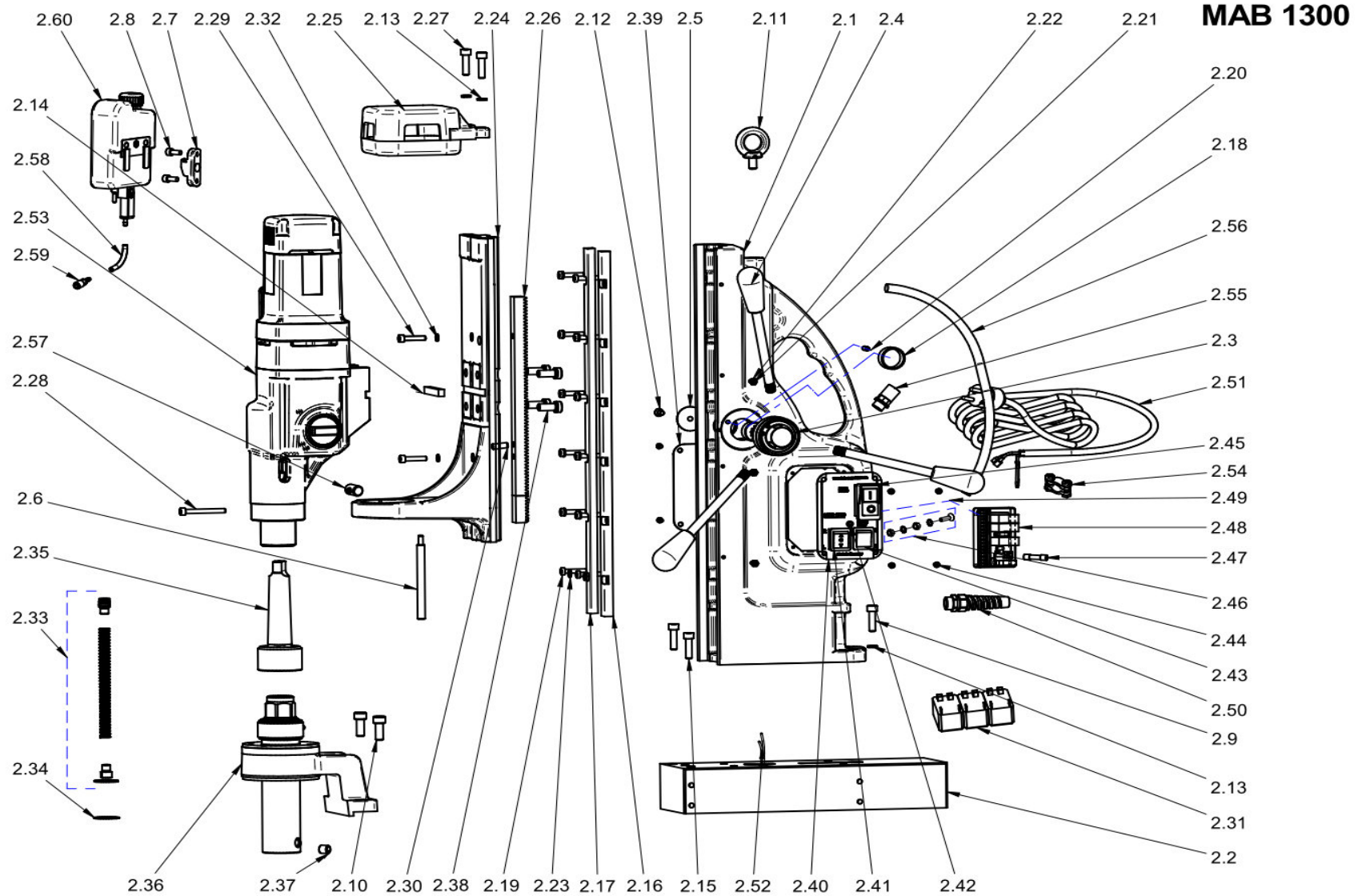

Pos. No.	Article no.	Description	pc
2.1	6030011	Housing for guide rails both sides screwed	1
2.2	6030071	Magnet with indicator	1
2.3	ZPA 403	Power Assistant	1
2.4	6010542	Handle rod with knob	3
2.5	6010221	Washer for gear wheel 10,5x35x1,5	1
2.6	7011771	Stop pin 122mm	1
2.7	6015621	Holder for magnet without screws for cutting oil tank ZKK 100	1
2.8	6011491	Hexagon socket M5x12 DIN 912	2
2.9	6050101	Hexagon socket M8x30 DIN 912	1
2.10	7011721	Hexagon socket M10x25 DIN 912	2
2.11	7011711	Ring screw SC M10	1
2.12	6010231	Screw M6x16 ISO 7047	1
2.13	6010571	Spring washer 8,2 DIN 7980	3
2.14	4000241	T-fixture	1
2.15	6010621	Hexagon socket M8x25 DIN 912	2
2.16	6030051	Guide rail right, screwed, 6 holes	1
2.17	6030041	Guide left right, screwed, 6 holes	1
2.18	6013871	Bush bearing 28,05H7x32x16	2
2.19	6050141	Hexagon socket M6x25 DIN 7984	12
2.20	6015041	Set screw M6x16 DIN 913	2
2.21	6010041	Set screw M5x16 DIN 913	4
2.22	6010031	Nut M5 DIN 934	4
2.23	6050151	Washer 6,4x11x1,6 DIN 433	12
2.24	6030021	Dovetail carriage with counterholder	1
2.25	6030081	Cap for motor	1
2.26	6030031	Rack	1
2.27	6050241	Hexagon socket M8x35 DIN 912	2
2.28	6010481	Hexagon socket M6x55 DIN 912	1
2.29	6010111	Hexagon socket M6x25 DIN 912	2
2.30	6015051	Hexagon pin 6m6x14 DIN 6325	1
2.31	7011851	Relais 30A for control board 110V	3
2.32	6010021	Spring washer 6,1 DIN 7980	2
2.33	6010761	Spring with washer	1
2.34	6010771	Circlip ring 32W	1
2.35	6030101	Hexagon adaptor MT4	1
2.36	6030091	Counterholder including industrial arbor	1
2.37	6010781	Set screw M12x10 DIN 913	2
2.38	6013451	Hexagon socket M10x30 DIN 7984	4
2.39	7011831	Cover of housing, back side	1
2.40.1	7011941	Switch plate front side for version 110V	1
2.40.2	7011472	Switch plate front side for version 230V	1
2.41	7010482	Rocker switch right/left	1
2.42	7010101	LED display for indicator red/green	1
2.43	7010142	Magnet switch, 4 connection terminals	1
2.44	7010081	Screw M4x8 DIN 966	8
2.45.1	7010111	Actuator 110V	1

Pos. No.	Article no.	Description	pc
2.45.2	7010801	Actuator 230V	1
2.46	7010061	Earthing complete	1
2.47	7010131	Fuse 2A, 5x20	1
2.48.1	7010163	Control board with 3 relais 110V	1
2.48.2	6012152	Control board with 3 relais 230V	1
2.49.1	7011761	Switch plate complete with PC board 3 Relais 110V	1
2.49.2	7011751	Switch plate complete with PC board 3 Relais 230V	1
2.50	7010031	Mains cable gland PG 11	1
2.51.1.1	7010052	Connection cable 110V with GB-plug	1
2.51.2.1	7010242	Connection cable 110V with US-plug	1
2.51.1.2	7010042	Connection cable 230V complete with plug	1
2.52	6012171	Indicator with cable	1
2.53.1.1	5001312	Motor complete 110V until May 2012	1
2.53.2.1	5001313	Motor complete 110V until December 2012	1
2.53.3.1	5001314	Motor complete 110V since December 2012	1
2.53.2.2	5001302	Motor complete 230V until May 2012	1
2.53.3.2	5001303	Motor complete 230V until December 2012	1
2.53.4.2	5001304	Motor complete 230V since December 2012	1
2.54	4010291	Cord grip	1
2.55.1	7050041	Glandg PG9 IP66 for version 110V	1
2.55.2	7010021	Gland PG 9 for version 230V	1
2.56	7010001	Cable protection tube 440mm	1
2.57	6050201	Plug with thread	1
2.58	ZSS 200SL	Cooling tube blue, long 480 mm	1
2.59	ZSS 200K	Quick change coupling	1
2.60	ZKK 101	Coolant reservoir with tap	1

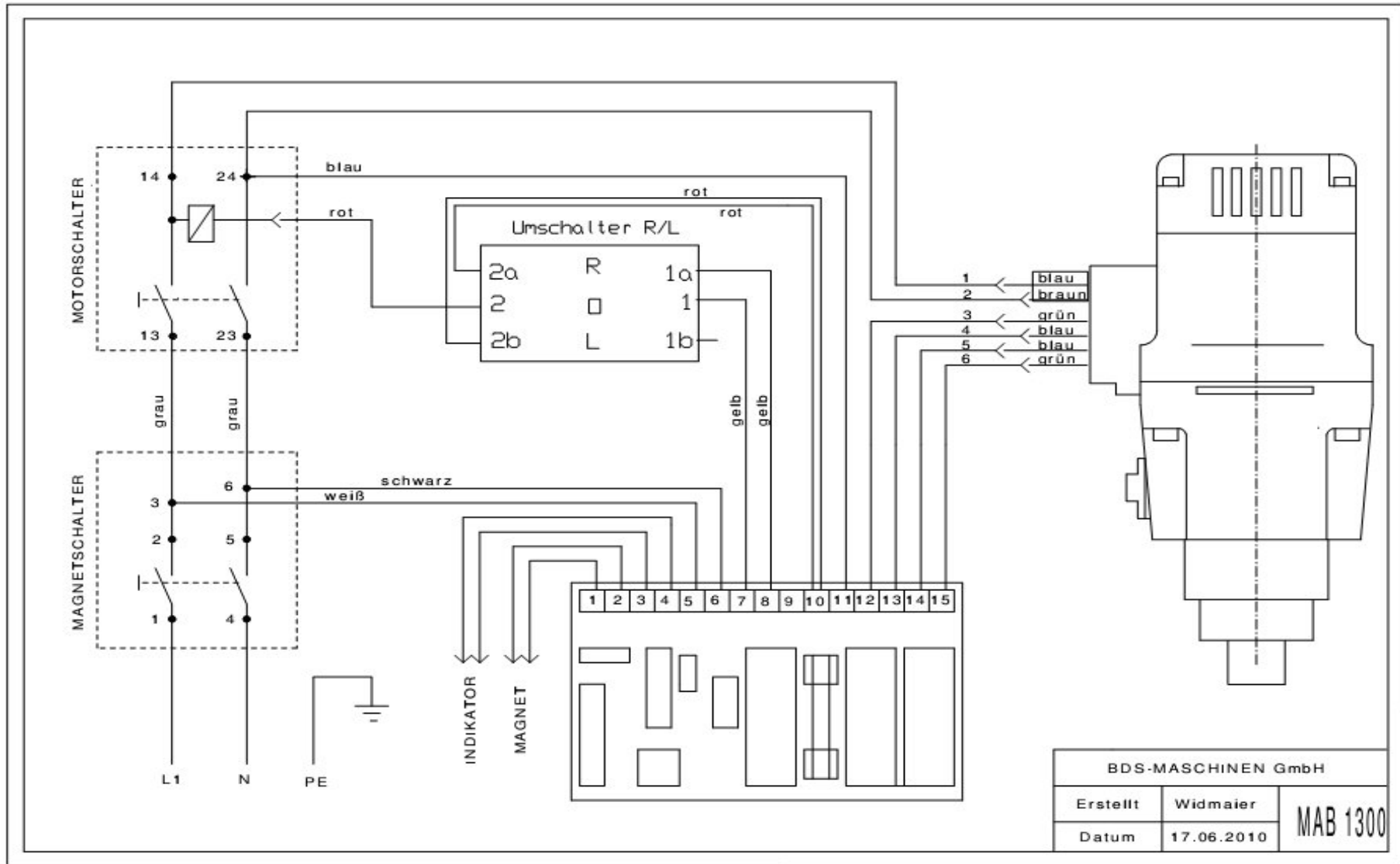

BDS-MASCHINEN GmbH		
Erstellt	Widmaier	MAB 1300
Datum	17.06.2010	