

Translation of the Original Operating Manual

AutoCUT 500



Contents **Page**

Original operating instructions 3



Table of Contents

Foreword	4	Changing tools	23
Instructions for use	4	Using	26
Copyright	4	Switching the machine ON/OFF	26
Safety warning structure	5	Setting the feed	26
Intended use	6	Setting the swarf guard	28
Liability disclaimer	6	Assembling the swarf bin	29
Safety	7	Chamfer width/milling angle ratio	30
Fundamental safety precautions	7	Eliminating blockages	30
Danger of electric shock	8	Cleaning	31
Risk of injury	9	After using	31
Avoiding damage	10	Maintenance	32
Transporting the machine	11	Setting the v-belt tension	32
Safety installations	12	Replacing the v-belt	34
Personal protective equipment	12	Customer service/service	34
Components/delivery contents	13	Troubleshooting	35
Machine overview	13	Faults - causes and remedies	35
Accessories	14	Storage/disposal	36
Operating elements	15	Storage	36
Before using for the first time	16	Disposal	36
Transport inspection	16	Appendix	37
Rotation direction of the milling motor	16	Technical data	37
Dressing with the machine	17	EC Declaration of Conformity	38
Installing	18		
Safety measures	18		
Checking the properties of the workpiece	18		
Setting up the machine	19		
Assembling the guide rails	20		
Aligning the guide rails	21		
Setting the milling head	21		
Setting the cutting depth	22		

Foreword

By purchasing this machine, you have decided in favour of a quality product whose engineering and sturdiness have been designed to meet the high demands of day-to-day professional use.

Read all the information contained here to quickly familiarise yourself with the machine and to make full use of its functions.

This machine will serve you for many years to come if you handle and treat it properly.

Instructions for use

These operating instructions are part of the welding edge milling machine AutoCUT 500 (hereinafter referred to as the machine) and contains important instructions for setup, safety, intended use and care of the machine.

These operating instructions must always be kept in the vicinity of the machine. They must be read and observed by all persons entrusted with operation, troubleshooting and/or cleaning of the machine.

Keep these operating instructions and pass them onto the next owner of the machine.

Copyright

This document is protected by copyright.

Any duplication or reprinting, in whole or in part, as well as reproduction of the illustrations, even in modified form is only permitted with the written approval of the manufacturer.

Safety warning structure

The following warnings are used in these operating instructions:

DANGER

A warning of this category indicates an impending dangerous situation.

If the dangerous situation is not avoided, it may lead to serious injury or even death.

- ▶ Follow the instructions in this warning to avoid the danger of serious injury or even death.

WARNING

A warning of this category indicates a potentially dangerous situation.

If the dangerous situation is not avoided, it may lead to injuries.

- ▶ Follow the instructions in this warning to avoid the risk of injury.

CAUTION

A warning of this category indicates potential material damage.

If the situation is not avoided, it may lead to material damage.

- ▶ Follow the instructions in this warning to avoid material damage.

NOTE

- ▶ A note indicates additional information that simplifies the use of the machine.

Intended use

The machine is only intended for milling welded edges. The machine may only be operated in a horizontal position.

Any use other than previously stated is considered as improper use.

WARNING

Danger from use for other than the intended purpose!

If not used for its intended purpose and/or used in any other way, the machine may be or become a source of danger.

- ▶ Use the machine only for its intended purpose.
- ▶ Observe the procedures described in these operating instructions.

No claims of any kind will be accepted for damage or injury resulting from use of the machine for other than its intended purpose.

The risk must be borne solely by the machine owner.

NOTE

- ▶ If used commercially, pay attention to compliance with the accident prevention and occupational safety regulations.

Liability disclaimer

All technical information, data and instructions for commissioning, operation and maintenance of the machine contained in these operating instructions represent the latest status at the time of printing.

The manufacturer assumes no liability for damage or injury resulting from failure to observe the operating instructions, use for other than the intended purpose, unprofessional repairs, unauthorised modifications or use of non-approved spare parts and accessories, tools and lubricants.

Safety

 CAUTION

When using electrical tools, the following fundamental precautions must be taken to protect against electric shock and the risk of injury and fire!

Fundamental safety precautions

- Do not use the machine in flammable or potentially explosive environments.
- Persons who are unable to operate the appliance due to their physical, mental or motor response abilities may only use the appliance under supervision or instruction by a responsible person.
- Children must not be allowed to use the machine.
- Inspect the machine for visible signs of damage before use. Do not use a damaged machine.
- Before beginning work, check the function of the switches on the machine.
- Repairs to the mains cable may only be carried out by a qualified electrician.
- Repairs to the machine may only be carried out by an authorised specialist workshop or by the works after-sales service. Unqualified repairs can lead to considerable danger for the user.
- Repairs to the machine during the warranty period may only be carried out by a service centre authorised by the manufacturer otherwise the guarantee will be invalidated.
- Defective parts may only be replaced with original spare parts. Only original spare parts guarantee that the safety requirements are met.

- Do not leave the machine unsupervised during operation.
- Store the machine in a dry, temperate location out of the reach of children.
- Do not leave the machine standing outdoors and do not expose it to moisture.
- Make sure that your work area is sufficiently lit (>300 Lux).
- Do not use low power machines for heavy working.
- Make sure that your workplace is clean.
- Keep the machine clean, dry and free of oil and grease.

Danger of electric current

DANGER

Danger from electric current!

Contact with live wires or components could lead to serious injury or even death!

Observe the following safety precautions to avoid any danger from electric current:

- ▶ Do not open the housing of the machine. Risk of electric shock if live terminals are touched.
- ▶ Never immerse the machine or the plug into water or other liquids.
- ▶ Only use extension leads or cable drums with a cable cross-section of 1.5 mm².
- ▶ Only use extension leads that are approved for the place of work.
- ▶ Check the condition of the extension lead regularly and replace if damaged.
- ▶ Avoid direct body contact with grounded parts (e.g., tubes, radiators, steel girders) to reduce the risk of electric shock in the event of a defect.

Risk of injury

 **WARNING****Improper handling of the machine increases the risk of injury!**

Observe the following safety precautions to avoid injuring yourself and/or others:

- ▶ Operate the machine only with the protective equipment stipulated in these operating instructions (see section **Personal protective equipment**).
- ▶ Remove loose jewellery before beginning work. Wear a hair net if you have long hair.
- ▶ Always switch off the machine before changing tools, performing maintenance or cleaning. Wait until the machine has come to a complete standstill.
- ▶ Always remove the plug from the mains socket before changing tools, cleaning or performing maintenance work, in order to avoid unintentional starting of the machine.
- ▶ Do not put your hand into the machine while it is in operation. Remove swarf only when the machine is at a standstill.
- ▶ Do not allow the connecting cable to hang over edges (trip wire effect).

Preventing damage

CAUTION

Potential damage to property if the machine is improperly used!

Observe the following instructions to avoid damage:

- ▶ Before connecting the machine, compare the connection data (voltage and frequency) on the rating plate with those of your mains power supply. The data must correspond in order to avoid damage to the machine.
- ▶ Always use the handles to carry the machine and not the connecting cable.
- ▶ Do not pull the mains cable to remove the plug from the mains socket.
- ▶ Do not crush the connecting cable.
- ▶ Do not expose the connecting cable to heat or chemical liquids.
- ▶ Do not pull the connecting cable across sharp edges or hot surfaces.
- ▶ Lay the connecting cable in such a way that it cannot be caught by the running machine.

Transporting the machine



WARNING

Danger resulting from the heavy weight of the machine!

Due to the heavy weight of the machine, observe the following instructions

- ▶ Only transport the machine with a suitable means of transport.
- ▶ Lifting the machine manually should be carried out by two persons.
- ▶ When transporting the machine with a crane, use suitable lifting equipment. Pay attention to the carrying capacity of the lifting equipment.

The machine is equipped with carrying handles (4 and 10) for transporting.

Loop the sling lifting gear through the carrying handle (4) at the milling motor to transport with a crane.

Safety equipment

Overload protection





A motor circuit breaker protects the feed motor from overloading.

Setting the swarf guard

The machine is equipped with a swarf guard that prevents swarf from spinning out.

Personal protective equipment

Wear the following protective equipment at all times when operating the machine:

Symbol	Meaning
	Close-fitting work protection clothing with a low tear strength
	Goggles for protecting eyes against flying parts and liquids
	Safety shoes for protecting feet against falling objects.
	Working gloves for protection against injury

Wear the following additional protective equipment during special operations:

Symbol	Meaning
	Ear protection in areas with high noise emission > 80 db(A)

Components / delivery contents

Machine overview

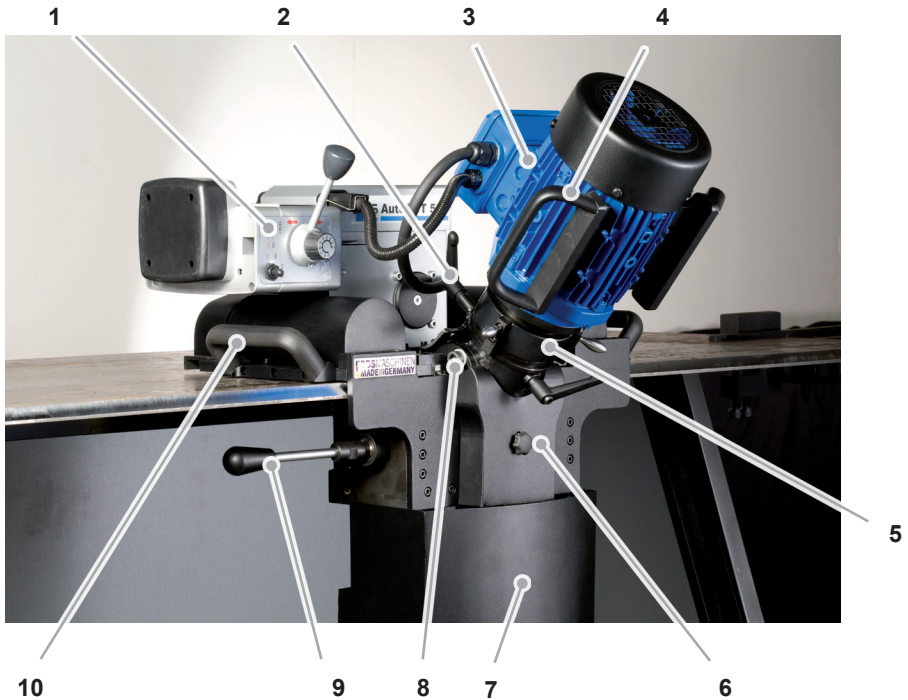

1	Feed unit	6	Swarf guard
2	Milling head locking mechanism	7	Swarf bin
3	Milling motor	8	Milling angle setting
4	Milling motor carrying handle	9	Switch lever for the guide roller
5	Setting the cutting depth	10	Carrying handle

Accessories

ENGLISH

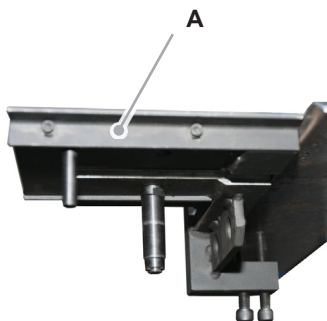

A	Left guide rail	Torx pin spanner (not illustrated)
	Right guide rail (not illustrated)	Transport case (not illustrated)
	Retaining pin (not illustrated)	Operating instructions (not illustrated)

Operating elements

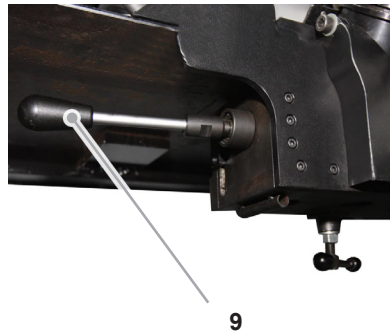
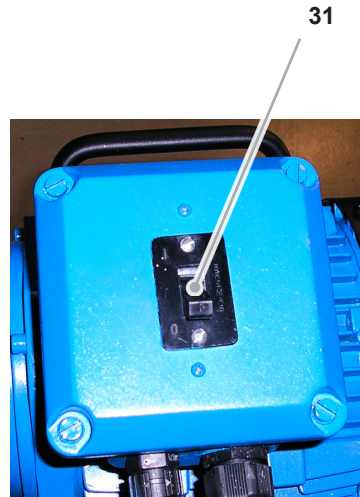
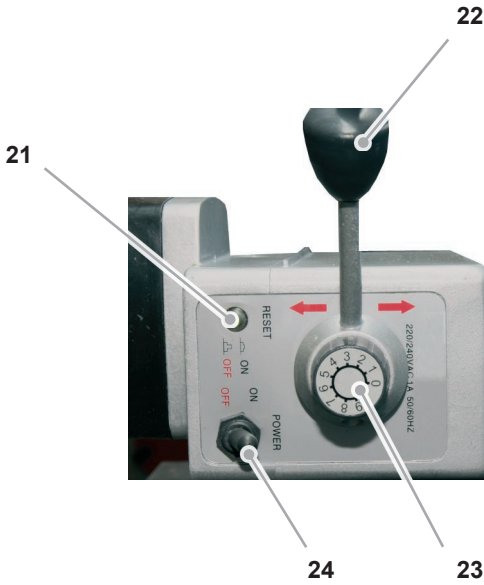

21	RESET: reset after triggering of the circuit breaker	31	Milling motor on/off switch
22	Feed direction switchover	9	Switch lever for the guide roller
23	Feed motor rotation speed setting		
24	Feed motor on/off switch		

Before using for the first time

Before using for the first time

Transport inspection

As standard, the machine is supplied with the components indicated in the section "Components/delivery contents".

NOTE

- ▶ Check for visible signs of damage or missing items on delivery. Report an incomplete or damaged delivery to your supplier/retailer immediately.

Checking the rotation direction of the milling motor

The machine may only be operated with a clockwise rotating field. To check, proceed as follows:

- ◆ Insert the plug into the mains socket.
- ◆ Switch on the machine briefly, see section **Switching the machine on/off**.
- ◆ Check the rotation direction (clockwise) of the milling motor

⚠ DANGER

Danger from electric current!

Contact with live wires or components could lead to serious injury or even death!

Observe the following safety precautions to avoid any danger from electric current:

- ▶ Ask a qualified electrician to check that the mains socket is able to supply a clockwise rotating field.

Milling with the machine

For milling, proceed as follows:

- ◆ Align the workpiece to be processed horizontally and secure it.

CAUTION

Potential damage to property if the machine is improperly used!

Observe the following instructions to avoid damage:

- ▶ Lay the connecting cable in such a way that it cannot be caught by the running machine.

- ◆ Position the machine at the workpiece, see section ***Positioning the machine***.
- ◆ Mount the guide rails, see section ***Mounting the guide rails***.
- ◆ Set the milling angle and the cutting depth, see section ***Setting the milling angle*** and ***Setting the cutting depth***.
- ◆ Set the feed, see section ***Setting the feed***.
- ◆ Set the swarf guard and mount the swarf bin, see section ***Setting the swarf guard*** and ***Setting the swarf bin***.
- ◆ Switch on the machine, see section ***Switching the machine on/off***.

NOTE

Observe the following instructions:

- ▶ Pay attention to the production of swarf.
- ▶ Empty and clean the swarf bin regularly.

The feed motor switches itself off after reaching the end position.

- ◆ Switch off the machine, see section ***Switching the machine on/off***.

NOTE

Observe the following instructions:

- ▶ The chamfer width is dependent on the chamfer angle and the cutting depth set. Refer to the table on page 30 for setting values.

Setting up

This section contains important instructions on required preparation before starting setup work.

Safety measures

WARNING

Risk of injury from a falling machine.

Observe the following safety instructions to avoid any danger.

- ▶ The machine may only be operated in a horizontal position.
- ▶ Secure the workpiece.

Checking the properties of the workpiece

The surface of the workpiece must meet the following requirements:

- The surface must be smooth and may not have any burn points, slag, welding joints or similar.

NOTE

- ▶ Before beginning with milling, remove surface unevenness.

Positioning the machine

WARNING

Danger resulting from the heavy weight of the machine!

Due to the heavy weight of the machine, observe the following instructions

- ▶ Only transport the machine with a suitable means of transport.
- ▶ Lifting the machine manually should be carried out by two persons.
- ▶ When transporting the machine with a crane, use suitable lifting equipment. Pay attention to the carrying capacity of the lifting equipment.

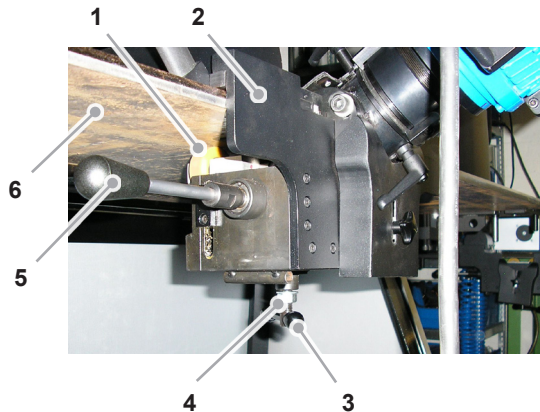

- ◆ Move the milling head to the upper end position, see section **Resetting the milling head**.
- ◆ Loosen the lock nut (4) and the thumb screw (3).
- ◆ Position the machine at the edge of the workpiece (6) and push the stop plate (2) up to the working edge.
- ◆ Turn the thumb screw (3) until the castors (6) touch the workpiece and then make a further half turn.
- ◆ Secure the thumb screw with the lock nut (4).
- ◆ Check for free movement of the guide roller (5) switch lever. If necessary, loosen the thumb screw (3) slightly.

Mounting the guide rails

NOTE

- ▶ Mount the left guide rail on the left side of the workpiece and the right guide rail on the right side of the workpiece.

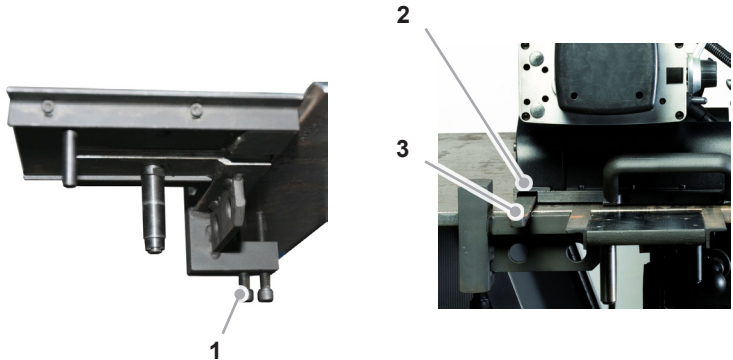

- ◆ Mount the guide rails onto the workpiece.
- ◆ Switch on the feed and move the machine to the end position. The guide rails are then automatically aligned.
- ◆ Align the guide rail so that the rail (3) is in line with the guide (2) of the machine.
- ◆ Tighten both fastening screws (1) until they touch the workpiece. The rail should still be movable.
- ◆ Switch on the feed, move the machine away from the guide rail and switch off the feed. Pay attention to the position of the guide roller (8) switch lever, see section **Setting the feed**.
- ◆ Check whether the guide rail is at the side of the workpiece edge.
- ◆ Tighten both fastening screws (1).
- ◆ If the guide rail is not at the same height as the workpiece surface, align it, see section **Aligning the guide rail**.
- ◆ Repeat the procedure for the other guide rail.

Aligning the guide rail

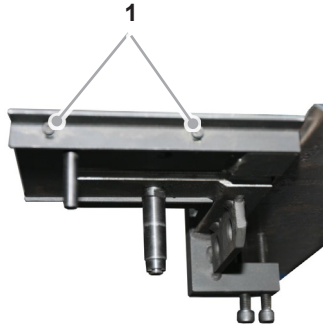

- ◆ Remove each of the 2 fastening screws (1) on both sides of the guide rail.
- ◆ Adjust the height of the guide rail to the height of the work-piece surface.
- ◆ Tighten the 4 fastening screws (1).

Setting the milling head

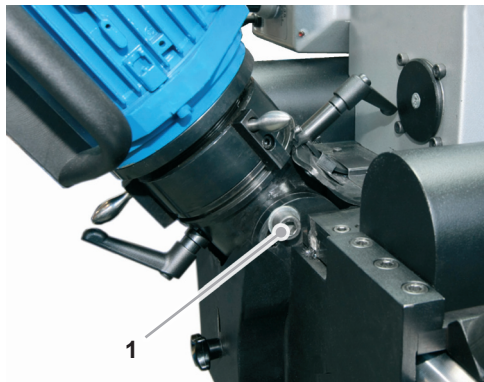

- ◆ Move the milling head to the upper end position, see section **Resetting the milling head**.
- ◆ Move the swarf guard to the lower position.
- ◆ Remove the locking mechanism (1) on both sides of the milling unit.
- ◆ Set the desired milling angle.
- ◆ Tighten the locking mechanism (1) on both sides of the milling unit.

Setting the cutting depth

Resetting the milling head

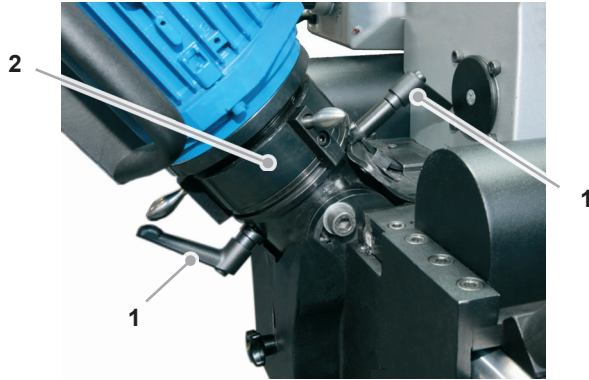

- ◆ Remove both clamping levers (1) on the upper and lower side of the milling unit.

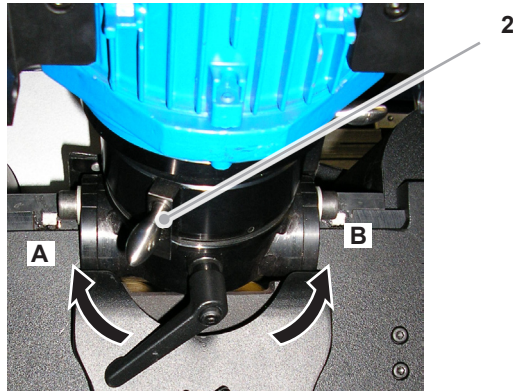

- ◆ Turn the setting ring (2) clockwise (A) up the stopper.

Setting the cutting depth

- ◆ Turn the setting ring (2) anticlockwise (B) until the milling head touches the workpiece.
- ◆ Switch on the feed and move the machine to the left end position.
- ◆ Set the desired cutting depth by turning the setting ring (2) anticlockwise (B).

NOTE

- ▶ A complete turn corresponds to a setting of 1.5 mm.

- ◆ Tighten both clamping levers on the upper and lower side of the milling unit.

Tool change

 WARNING**Risk of injury!**

- ▶ Do not use damaged, soiled or worn tools.
- ▶ Only perform tool changing when the machine is switched off and not moving. Pull the plug out of the mains socket.
- ▶ Only use tools, adapter and accessories that match the machine.

Dismantle the milling unit

NOTE

► Dismantling the milling head is not necessary when changing or turning the reverse plates.

- ◆ Move the swarf guard to the lower position.
- ◆ Press the spring bracket (1) upwards and pull the plug out.

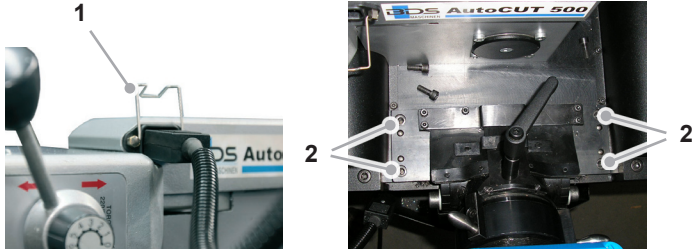

- ◆ Unscrew the four fastening screws (2).
- ◆ Remove the milling unit from above.



- ◆ Insert the retaining pin into the opening (3) to lock the spindle.
- ◆ Turn the shaft until the retaining pin snaps into the shaft.

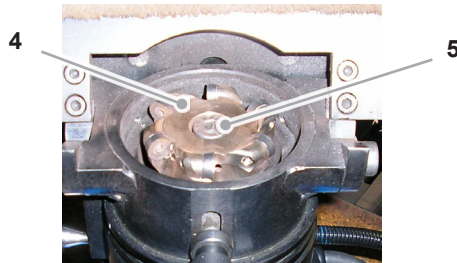

- ◆ Remove the fastening screws (5) and remove the milling head (4).

Turning the reversing plates

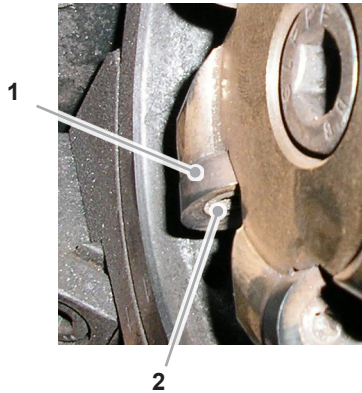

- ◆ Dismantle the milling unit, see section *Dismantling the milling unit*.
- ◆ Turn back the setting ring until you can remove the reversing plates with a Torx pin spanner.
- ◆ Remove the fastening screws (2), turn the reversing plate (1) and tighten the fastening screw (2).
- ◆ Repeat this work step for all reversing plates of the milling head.

Replacing the reversing plate

When the reversing plate is completely worn, it must be replaced by a new one:

- ◆ Unscrew the fastening screw (2) and remove the reversing plate.
- ◆ Insert the reversing plate and tighten the fastening screws again.

Mounting the milling unit

- ◆ Pull out the retaining pin
- ◆ Insert the milling unit into the machine and tighten the four fastening screws.

Operation

Switching the machine ON/OFF



⚠ CAUTION

Before switching on, check whether the retaining pin has been removed.

- ◆ Move the on/off switch (31) to position 1 to switch on the machine.
- ◆ Move the on/off switch (31) to position 0 to switch off the machine.

Setting the feed

Feed direction

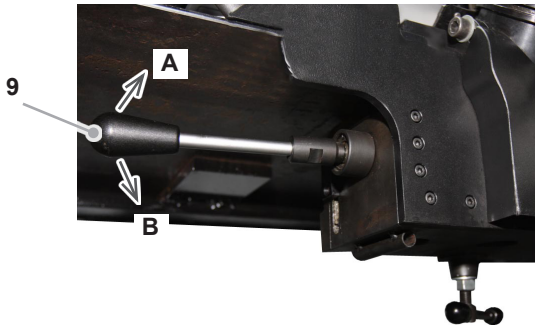

- ◆ Push the lever (22) on the feed unit to the left or to the right to set the corresponding feed unit on the drive.
- ◆ Push the guide roller switch lever (9) forwards or backwards according to the desired feed direction:
feed direction from left to right = position A (front)
feed direction from right to left = position B (back)

Feed rate

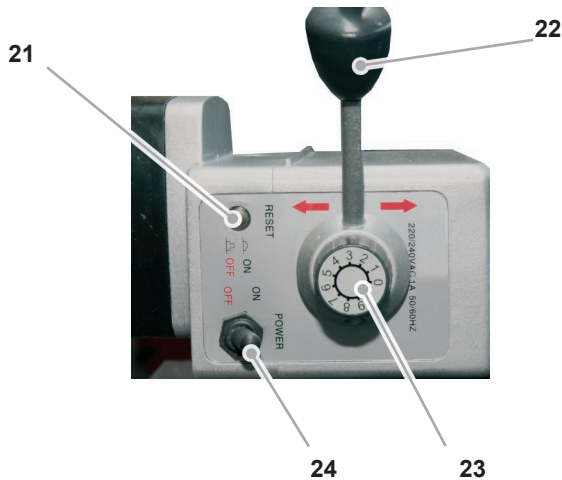

- ◆ Set the desired feed rate by turning the regulator (23): clockwise: increase rate, anticlockwise: decrease rate

NOTE

- ▶ Begin the milling procedure with a low feed rate (stage 2) and increase stepwise as necessary, depending on the cutting depth.
- ▶ Processing always takes place from left to right. The return takes place without infeed.

Switch feed motor on/off

- ◆ Move the on/off switch (24) to the ON position to switch on the feed motor.
- ◆ Move the on/off switch (24) to the OFF position to switch off the feed motor.

Resetting the feed motor

- ◆ Press the RESET button (21) to reset the feed motor controller, e.g., after triggering the motor circuit breaker.

Setting the swarf guard

⚠ WARNING

Risk of injury from swarf spinning out.

- ▶ Only operate the machine with correctly mounted swarf guard.

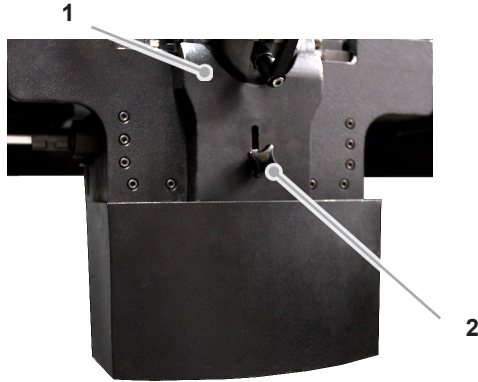

- ◆ Remove the rotary knob (2).
- ◆ Push the swarf guard (1) upwards to the stopper.
- ◆ Tighten the rotary knob (2).

Mounting the swarf bin

⚠ WARNING

Risk of injury from swarf spinning out.

- ▶ Only operate the machine with a correctly mounted swarf bin.

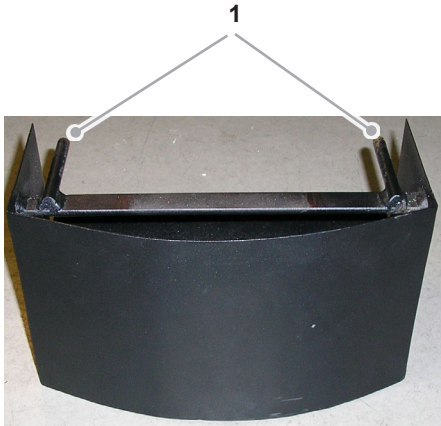

- ◆ Insert both pins (1) into the holes on the underneath of the milling unit.

Eliminating blockages

ENGLISH

Chamfer width/milling angle ratio

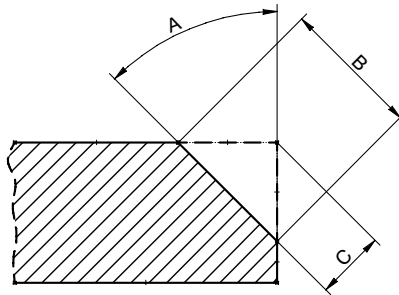

Cutting depth C [mm]	Milling angle A	Chamfer width B [mm]			
		15°	30°	45°	60°
1.5		6.0	3.5	3.0	3.5
3.0		12.0	7.0	6.0	7.0
4.5		18.0	10.5	9.0	10.5
6.0		24.0	14.0	12.0	14.0
7.5		24.0	17.5	15.0	17.5
9.0		24.0	21.0	18.0	21.0
10.5		24.0	24.5	21.0	24.5
12.0		24.0	28.0	24.0	28.0
13.5		24.0	31.5	27.0	31.5
15.0		24.0	31.5	27.0	31.5

Eliminating blockages

WARNING

- ▶ Put protective gloves on before starting work.
- ◆ Switch off the machine and pull the plug out of the mains socket.
- ◆ Release the workpiece from the machine.
- ◆ Remove swarf and check the milling head.

Cleaning

⚠ WARNING

- ▶ Switch off the machine and pull the plug out of the mains socket before starting maintenance and cleaning.
- ▶ Due to the risk of injury to persons or damage to the machine, cleaning with compressed air is prohibited.

CAUTION

- ▶ Never immerse the machine in water or other liquids.

After every use

- ◆ Remove the swarf bin.
- ◆ Empty and clean the swarf bin
- ◆ Remove swarf on the machine.
- ◆ Clean the tools and the brushes on the underneath of the milling unit.
- ◆ Move the milling head to the upper end position, see section ***Resetting the milling head.***
- ◆ Tighten both clamping levers on the upper and lower side of the milling unit.
- ◆ Clean the guide rollers.
- ◆ Put the machine and accessories into the transport case.

Maintenance

WARNING

Danger caused by unqualified repairs!

Unqualified repairs can lead to considerable danger for the user and cause damage to the machine.

- ▶ Repairs to electrical appliances may only be carried out by the works customer service or by specialists trained by the manufacturer.

- ◆ Check the following machine parts regularly for wear:
 - Milling head and reversing plates
 - Castors
 - Brushes
 - Pressure plates on the front stopping plate
 - Feed unit v-belt; re-tension, if necessary.

Setting the v-belt tension

Remove the v-belt cover

To remove the v-belt cover, proceed as follows

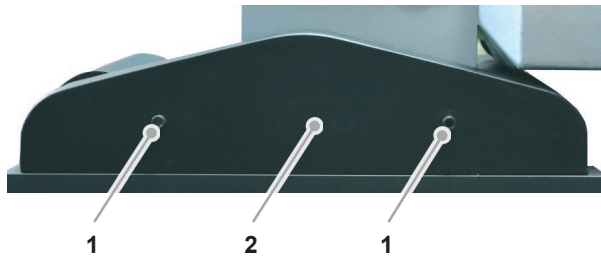

- ◆ Remove the fastening screws (1).
- ◆ Remove the cover (2).

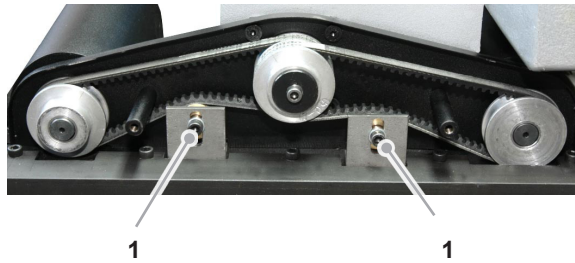

To set the v-belt tension, proceed as follows:

- ◆ Remove the fastening screws (1) of the counter-pressure rollers for the left or right v-belt.
- ◆ Set to the desired v-belt tension by raising or lowering the counter roller.
- ◆ Tighten the fastening screw (1) again.
- ◆ Fix the cover with both fastening screws.

Replacing the v-belt

To replace the v-belt, proceed as follows:

- ◆ Remove the v-belt cover, see section **Removing the v-belt cover**.

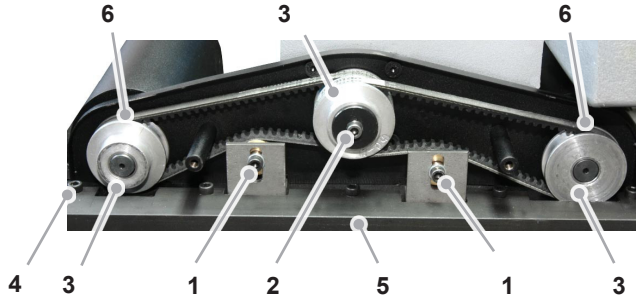

- ◆ Remove the fixing screw (1) for the counter-pressure rollers for both v-belts and move the counter-pressure rollers to the lower position.
- ◆ Unscrew the fastening screw (2) and both grub screws (6).
- ◆ Remove the five fastening screws (4) and take off the guide rail (5).
- ◆ Pull off the three drive rollers (3).
- ◆ Remove the old v-belt and put in a new v-belt.
- ◆ Attach the drive rollers (3).
- ◆ Mount the guide rail (5) and tighten the fastening screws (4).
- ◆ Screw in the grub screws (6) and the fastening screws (2).
- ◆ Set the v-belt tension, see section **Setting the v-belt tension**.

Customer service/service

If you have any questions for customer service/service, please contact BDS.

Troubleshooting

Fault causes and remedies

Fault	Possible cause	Remedy
The milling motor does not start after the on/off switch is pressed or stops during operation.	Plug not inserted into socket.	Insert the plug.
	Automatic circuit breaker tripped.	Switch on the automatic circuit breaker again.
The automatic circuit breaker in the electrical distribution board trips	Too many devices connected to the same power circuit.	Reduce the number of devices on the power circuit.
	The machine is defective.	Contact customer service.
The feed does not work.	Cutting depth is too large.	Reduce the cutting depth
	The feed motor plug is not inserted.	Insert the feed motor plug.
	The feed motor circuit breaker was tripped.	Eliminate the cause for overloading of the feed motor and press the RESET button (21).
	V-belt tension too low.	Increase the v-belt tension.
	V-belt is damaged.	Replace the v-belt.

NOTE

- ▶ If you cannot resolve the problem with the steps described above, please contact customer service.

Storage/disposal

Storage

If you do not intend to use the machine for a longer period of time, clean it as described in the section **Cleaning**. Store the machine and all its accessories in the transport case at a dry, clean and frost-free location.

Disposal

Disposal of the packaging

The packaging protects the machine against damage during transit. The packaging materials were selected according to environmental and waste disposal aspects and can therefore be recycled.



Recycling the packaging material for further use saves raw materials and reduces waste.

When no longer required, dispose of the packaging materials in accordance with the local regulations.

Disposal of the old machine

This product may not be disposed of in the domestic refuse within the European Union.



Dispose of the machine in accordance with the EC Directive 2002/96/EC-WEEE (Waste Electrical and Electronic Equipment).

Should you have any questions, please contact your local authority responsible for waste disposal.

Appendix

Technical data

Model	AutoCUT 500
Dimensions (L x W x H)	600 x 500 x 540 mm
Net weight, approx.	50 kg
Operating voltage	400 VAC / 50 Hz
Power	1100 W
Noise emission	92 - 98 db(A)
Rotating speed	2750 rpm
Feed	Automatic, continuously variable up to max. 500 mm/min
Chamfer angle	15° to 60° (continuously variable)
Chamfer width	max. 30 mm
Cutting tool	Face milling head with hard metal cutting inserts
Thermal protection	Yes
Workpiece thickness, max.	40 mm
Connecting cable length	2.8 m
Protection class	I

EC Declaration of Conformity

Name/address of the manufacturer:	BDS Maschinen GmbH Martinstraße 108 D-41063 Mönchengladbach
We hereby declare that the product	
Model:	Welding edge milling machine
Type:	AutoCUT 500
conforms to the following relevant regulations:	
<ul style="list-style-type: none"> ■ EC Directive 2006/42/EC on machinery ■ EU Directive 2004/108/EU on Electromagnetic Compatibility. 	
The following harmonised standards were applied in whole or in part:	
<ul style="list-style-type: none"> ● DIN EN ISO 12100-1 ● DIN EN ISO 12100-2 ● DIN EN 61029-1 ● DIN EN 61000-3 ● DIN EN 50082-1 ● DIN EN 55014-1 ● DIN EN 55014-2 ● DIN EN 55104 	
Responsible person for documentation according to EC Directive 2006/42/EC - Annex II Pt.A.2. was:	
<hr style="width: 60%; margin: 0 auto;"/> (Surname, forename, position in company of the manufacturer)	
Mönchengladbach, 3rd May, 2011	 Wolfgang Schröder, Technical Director <hr style="width: 30%; margin: 0 auto;"/> (Legally binding signature of the issuer)

BDS Maschinen GmbH

Martinstraße 108
D-41063 Mönchengladbach

Fon: +49 (0) 2161 / 3546-0

Fax: +49 (0) 2161 / 3546-90

Internet: www.bds-maschinen.de

E-mail: info@bds-maschinen.de
